

MileGate CEOP1

TDM Circuit Emulation Service for E1 connections via Ethernet/IP packet networks

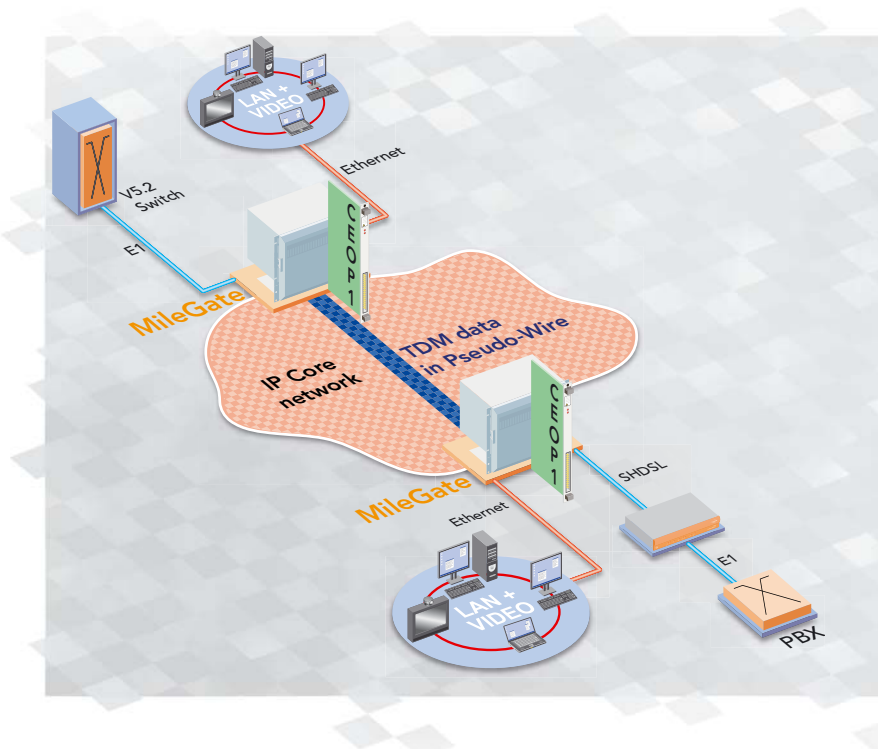

- 8 x E1 interfaces
- CES service with up to 8 x 2 Mbps Pseudo Wires
- Highly-accurate and stable clock recovery according to ITU-T G.823
- Precise and steady "hold-over" clock
- Designed for indoor and outdoor deployment
- All functions out of one network management system
- Compatible with PacketBand units

Despite the transition of many core networks to Ethernet/IP, legacy data interfaces are not losing their importance. Many applications will demand E1 interfaces further on, in order to continue to use the already installed equipment. Network operators wanting to save costs with an All-IP network must be able to distribute these legacy interfaces via Ethernet/IP.

Thus maximum saving potential can be realised without having to withdraw the well-known services from the client-base.

■ CESoP in MileGate

With its hybrid backplane MileGate provides native TDM and Ethernet services.

CEOP1 emulates TDM services via Ethernet/IP technology. CEOP1 transmits an arriving E1 data stream via Pseudo Wires together with data of other services over the IP core network. A CEOP1 or PacketBand unit can convert this data back to an E1 data stream at any position in the network.

■ Clock Recovery

With its highly-accurate algorithms the clock can be recovered from any arriving Pseudo Wire.

Thanks to the exact „hold-over“ function a high-precision clock signal can be delivered also during network failure.

■ Clock Algorithms

The CEOP1 supports three base algorithms designed for different network types.

One for high quality managed networks with low jitter (PDV) and packet loss, one for general networks with lower performance characteristics and one for applications, where the frequency stability is most important.

■ Safety Concept

MileGate offers fail safety in carrier-grade quality. For this purpose all modules come with decentral onboard power supplies. In addition the central module can be made redundant to guarantee for optimum fail safety.

■ One Management System

All MileGate functions are central managed via the management system UNEM/MCST or via a local access (CLI, XML, SNMP).

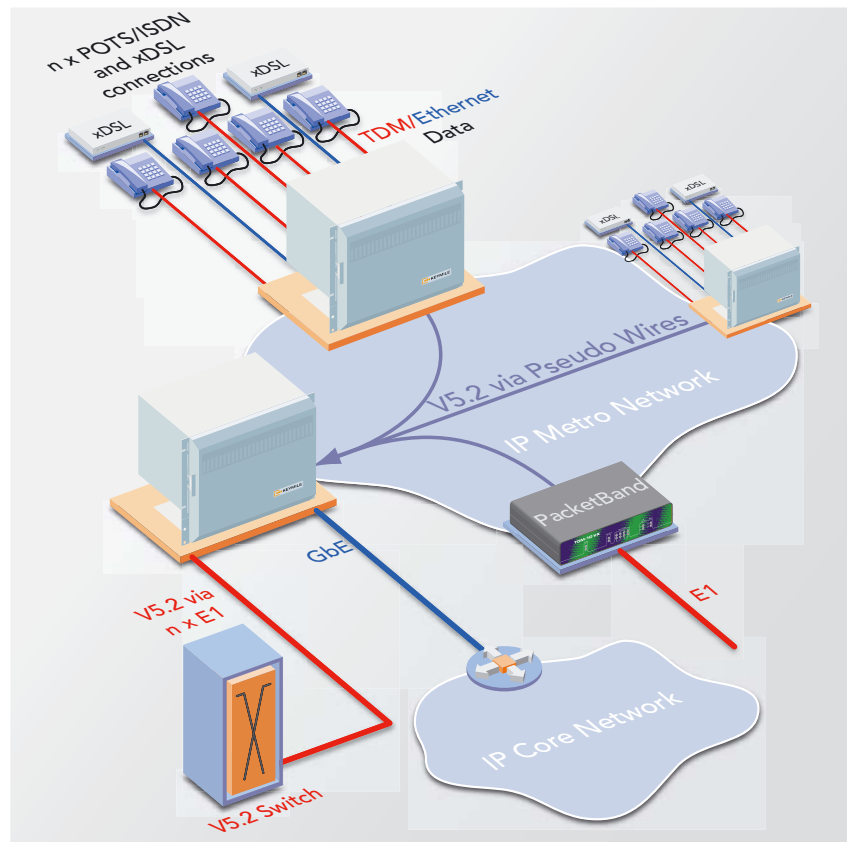

Technical Data

CESoP	
Circuit Emulation Service	SAToP (Structure Agnostic TDM over Packet) acc. to IETF RFC 4553
Pseudo-Wires	8 x 2 Mbps 2 Mbps clear channel (unstructured) or n x 64 kbps structured
QoS	According to 802.1p VLAN priority IP DiffServ (DSCP)
VLAN	Single tagged Transparent LAN Service (TLS) via VLANs acc. to TR-101
Timing and synchronization	According to ITU-T G.8261
Clock	
Adaptive	The network clock is recovered from the arriving data packets
Clock master (P12s, P0nc)	MileGate system clock is distributed via data packets
Transparent (P12x)	Clock of one G.703 interface will be transmitted transparently
Stability	24h holdover stability of ± 0.280 ppm (ITU-T Stratum 3)
E1 Interface	
Number of ports	8 G.703
Impedance	75 and 120 ohms
Transmission	2 Mbps transparent and n x 64 kbps
Jitter and wander	According to ITU-T G.823
Management	
MCST	For local management
UNEM	For central management
Power Supply	
Input voltage nominal (min/max)	-48/-60VDC (-40.5VDC ... -72VDC)
Operation Environment	
Temperature range and humidity	According to MileGate environmental specifications



Looking for more information?
 Find your local contact on www.keymile.com
 or contact us: info@keymile.com ...